

Vortex Simulates Inspection Robots for Game-changing PETROBOT Project

In the petrochemical industry, the inspection of pressure vessels and storage tanks is currently being done by human inspectors working inside these assets.

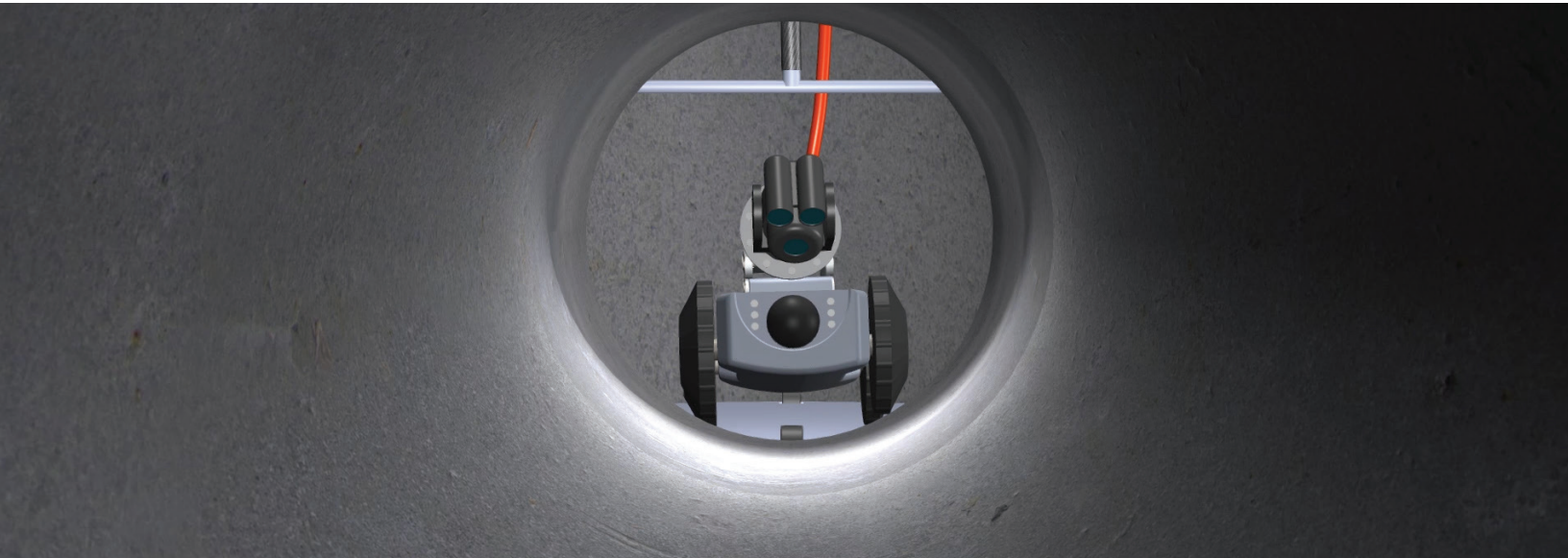

For safety reasons, these assets are taken offline and decoupled from live sections of the plant during inspection, and extensively cleaned to remove all products that can emit flammable or harmful gases. It's a task that would be best suited to inspection robots, if those robots existed. But these robots don't fully exist yet. The PETROBOT project is changing that. The EU-funded project was launched in 2013 by the European Commission and a consortium of ten companies including major oil and gas companies from the Netherlands, Norway, and North America. The goal: To develop a series of inspection robots for both offline pressure vessel inspection and online tank inspection. Semi-autonomous tethered crawlers and snake arm robots are currently being built with features ranging from inspection cameras, and ultrasonic and eddycurrent inspection technologies, to weld detection capabilities and onboard laser imaging systems for 3D scans of vessel interiors.

The Vortex™ Simulation Platform is playing a critical role in the project, says Dr. Timothy Black. He is the 3D Simulation Business Lead and a robotics inspection technologies engineer for Quasset, an asset management company located in the Netherlands. Quasset is one of the lead project members for PETROBOT and is managing the integration of these robots into the industry, as well as ensuring global market uptake and deployment of this technology. "Vortex simulation allows our clients to see, do, and plan prior to actually getting into the real world, so they can ask the what-if questions. They can do the analysis and minimize the risks. "We're using Vortex to say, OK, if you have this piece of technology, it can reach this far, it can see this far, it can travel in this configuration. But if you use this other piece of technology, you can do something different. And we can give them a comparison on that."

The Company

Based in the Netherlands, Quasset identifies and implements novel strategies in asset management and condition assessment solutions.

The Situation

Quasset is managing the integration of asset inspection robots into the petrochemical industry, as well as ensuring global market uptake and deployment of this technology.

The Solution

The Vortex Simulation Platform allows project participants to "see, do, and plan prior to actually getting into the real world, so they can ask the what-if questions."

"What we're essentially doing is performing feasibility studies to see if particular pieces of robotic and inspection technology can perform a task within an asset." Black says Quasset also uses the Vortex Simulation Platform to uncover and evaluate new robotic design requirements.

"We actually discovered some of the elements that the robots needed by using Vortex," says Black. "For example, we discovered that having more cameras on a particular robot is vital to showing where you are and what you're doing. Doing simulation prior to a 'real' inspection virtually allowed us to determine what configuration of the robot was optimal for deployment in the real world." Black says confidence in the Vortex simulations was also key to taking the new robotics technology past proof-of-concept. "The industry is careful when deploying new robotic technologies in the field," he explains. "There are a lot of factors when new technology is used in plants. You need to adhere to procedures, working practices, and safety rules, but also regulations on the plant level, as well as the national and international level. To tick all these boxes you have to be very sure that what you're deploying or the processes you're using are correct and most of all safe."

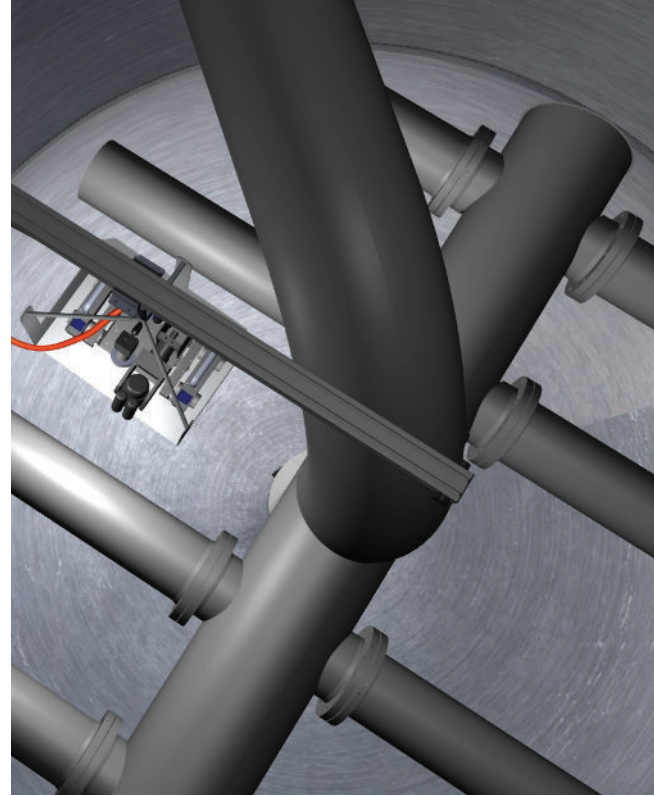

"So during our testing we actually performed technology trials in the real world, as well as simulations in the virtual world, and we validated the two processes against each other. "What Vortex does for us is show how things could work in the real world. That's one thing it really solves, compared to gaming engines for example, the physics engine is very reliable and accurate. A gaming engine can do physics, and the physics are improving all the time, but it's still 'higher-level' physics – physics to just make the game work. Whereas when Vortex does its computations, it actually gives you a really good answer – we're confident that if an object moves in the simulated world, it will move like that in the real world." The real-time simulation capabilities of Vortex provided other vital links in the engineering value chain, says Black, including human-in-the-loop testing and operational planning. "The real-time analysis is very important. Although it's computationally heavy, the real-time factor allows us to really get answers fast. "We currently use simulation to do preoperational planning – which enables the whole value chain to get together around the simulation."

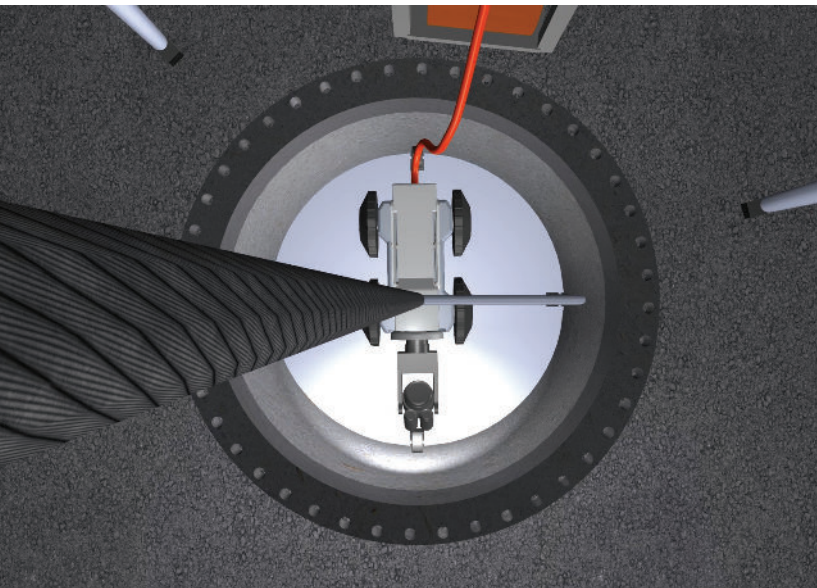

The operator of the technology can start conducting a virtual series of operations – everyone can see where you can drive, and what you can see, and how the lighting conditions work, and how the camera can zoom, and where we need to go. They can actually start planning for the best way to tackle their tasks. In the future, we're looking to integrate the whole chain into one system." The €6.2 million PETROBOT project is due to be completed in September 2016, and Black is confident it will change the way the petrochemical asset inspections are conducted.

"These will be commercially ready robots, available to the entire industry. That's why it's very important to show what these robots can do. We're looking at the big picture of how we can make a difference in our industry, and Vortex simulation is a key part of that."



info@cm-labs.com
cm-labs.com
T +1 514 287 1166

@vxsim

youtube.com/vortexsim

company/cm-labs-simulations

facebook.com/vxsim

Vortex® is a Canadian registered trademark of CM Labs Simulations, inc