

# Reach Stacker Simulator Training Pack

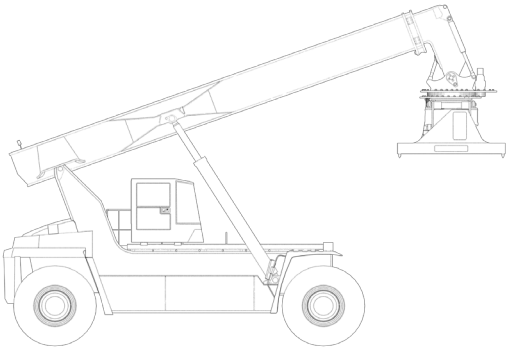

## Simulated equipment specs /

- Capacity:** 45 mT
- Wheelbase:** 6 m
- Container height:** Up to 5 containers on the first row

## Overview /

Designed to run on any Vortex port equipment simulator, CM Labs’ Reach Stacker Simulator Training Pack allows trainees to rapidly acquire operational skills in a pressure-free, safe learning environment. Transition faster and more effectively to the real equipment.

## Key features & benefits /

CM Labs’ solution for reachstacker training provides the most advanced training available, with exercises featuring complex lifts and different container types. The solution provides exercises for working with challenging container locations within a stack. 20-, 40-, and 45ft containers can be stacked five high in training scenarios, and the reachstacker can reach containers in the second and third rows.

**A progressive learning program** covering driving exercises and yard operations with ITVs and external trucks.

**Performance metrics and reporting** that provide trainers with real-time feedback on operator aptitudes and habits, along with overall scoring.

**Best-of-class lifting simulation** that ensures trainees understand how the equipment works and what is required for efficient operations.



## Smart Training Technology /

The Reach Stacker Simulator Training Pack incorporates CM Labs' Smart Training Technology™— resulting in a training solution that delivers the most transferable operator skills anywhere, outside the real equipment. It is the only solution on the market that can tip when the simulated equipment brakes or corners too fast, and that reacts realistically when loads are distributed unevenly.

Smart Training Technology is comprised of CM Labs' proprietary and patented algorithms, and includes real-time simulation features that are unique on the market. This means training is based on real data and real machines, and new operators reach full productivity levels up to 33% faster, according to our clients.

With a focus that goes far beyond basic controls familiarisation, the Reach Stacker Simulator Training Pack exposes operators to conditions that are challenging or unsafe to replicate outside the classroom.

The training pack allows trainers to introduce specific challenges at any time, including terminal congestion, overload conditions, twistlock malfunctions and container snags, and other issues that challenge a trainee's ability to react appropriately.



## Supported Simulator Hardware Platforms

The Reach Stacker Simulator Training Pack can be installed on any Vortex port equipment simulator hardware, with different configurations to meet your budget, space, and training requirements. Designed for years of 24/7 operator training, Vortex simulators are built to last.

**Vortex Trainer: Entry-level desktop training**

**Vortex Advantage: Motion-enabled training station**

**Vortex Master: High-immersion training**

## Progressive learning program

Designed in collaboration with port operator trainers, all exercises are designed to familiarize operators with basic control functions and techniques for loading and unloading various containers in a real port setting.

Learning outcomes include:

- ✓ Familiarization with bays, rows, & cell identification
- ✓ Manipulating 20-, 40-, and 45-foot containers
- ✓ Managing and avoiding overload situations
- ✓ Driving safely with loads
- ✓ Placing containers behind other containers
- ✓ Managing pendulum when using chains
- ✓ And more

## Performance measurement

The Reach Stacker Simulator Training Pack tracks all operating performance metrics during training exercises, and rolls them up into a single score that updates in real time. Port terminals and training schools can customise this scoring system to highlight their most important standards, so that new operators can ramp up even faster. Tracked metrics include:

- ✓ Number of containers moved
- ✓ Number of collisions
- ✓ Operator errors
- ✓ And more

Instructors can also generate reports based on customizable scoring parameters, and review against benchmarks or past training sessions.



Megamax STS  
Panamax STS  
Mobile Harbour Crane  
Ship Pedestal Crane

Internal Transfer Vehicle  
Forklift  
Rubber-tyred Gantry Crane  
Straddle Carrier

Reach Stacker  
Empty Container Handler  
...more at  
[cm-labs.com](http://cm-labs.com)